



High-Density, Rugged Connectors

Smaller Doesn't Mean Less

William "Billy" Rhea
Sr. Product Manager

1/23/2023



The term “rugged & reliable” is a common phrase used in countless marketing pieces within the electronic component industry. That distinction is also applied specifically to connectors, one of the core components of many electronic systems.



Because no easily-referenced grading system exists to distinguish truly rugged & reliable connectors from commercial-grade connectors only claiming to be, engineers must see through the marketing hype to determine a connector’s true nature.

Rugged and Reliable Design

- What makes a connector RUGGED?
 - Contact – size, durability, and performance
 - Design Features
 - Materials
- Development of new rugged interconnect solutions
 - VoC
 - SWaP-C
- Industry Applications
 - Smaller doesn't mean less



R Series – 3 amps



W Series – 5 amps



M Series – 3 amps



N Series – 1 amp



SInergy – 2 amps

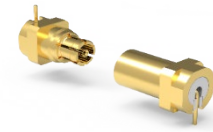

RockEt Series – 5 amps



Series 360 – 3 amps



MicroSI Series – 3 amps



verSI Series – 2 amps

Rugged Contact Base Material

Contact base materials play a central role in delivering proper contact normal force through spring performance, but also:

- Electrical conductivity
- Thermal conductivity
- Ease of fabrication
- Material costs

Beryllium Copper (BeCu), is the base material-of-choice for spring member contacts in ultra-high reliability connectors

- High-yield strength
- High hardness
- Added formability and spring stability
- Very high fatigue resistance, a critical facet of high-endurance components, especially under cyclic loads

Phosphor Bronze or **Brass** is often the material-of-choice for non-spring contact members such as pins

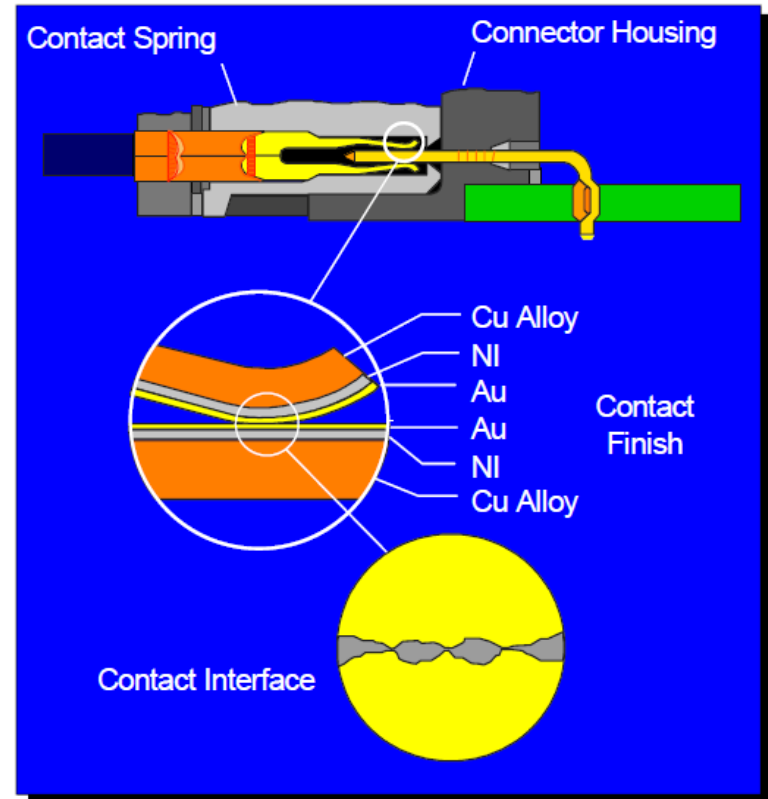

Rugged Contact Plating Material

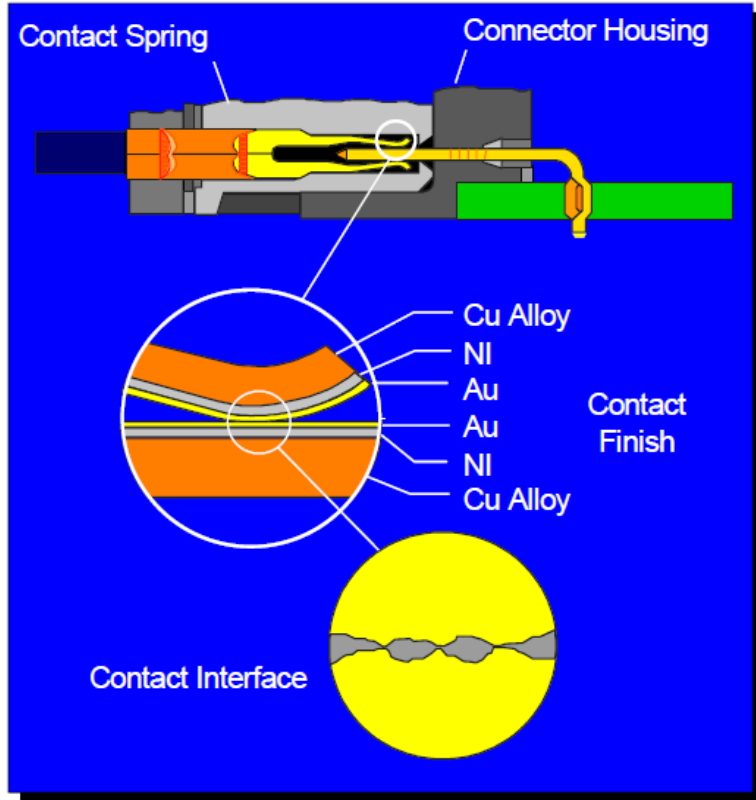

Contact plating, or metal used to coat the base material at the mating face, is classically gold due to its resistance to corrosion, thus sustaining consistent electrical conductivity.

Gold also provides a very durable connection provided a **50 μ in** coating thickness is used

Industrial grade connectors typically have gold thicknesses of less than **30 μ in**, typically **10-15 μ in**

Commercial grade connectors often use tin plating instead of gold plating. In addition, our rugged connectors have an added **Nickel under plate** to keep the copper from bleeding through.

Contact wipe is the distance that the spring member 'wipes' across the non-spring member when the pin and socket fully mate.

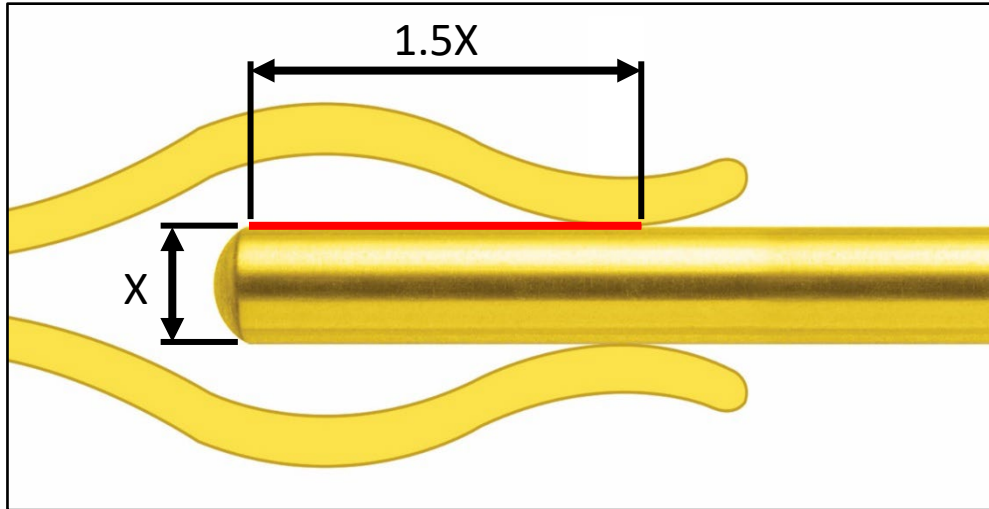

At AirBorn, we require the wipe distance to be a **minimum of 1.5 times the diameter of the pin**

- Removes any oxidation present for clean connection
- Provides mating tolerance to ensure electrical connection

What Makes A Rugged Contact?

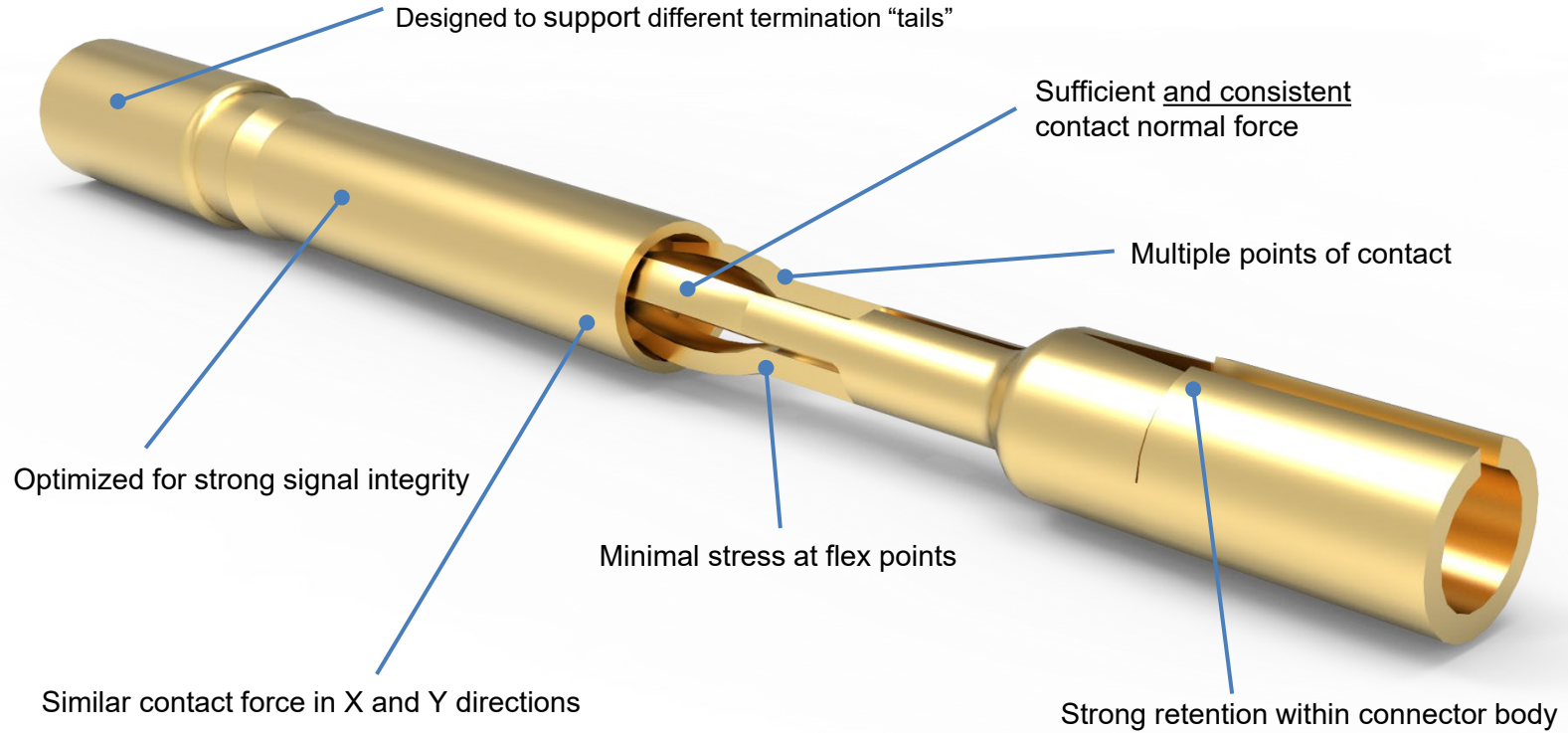

Science & engineering on a microscopic level.

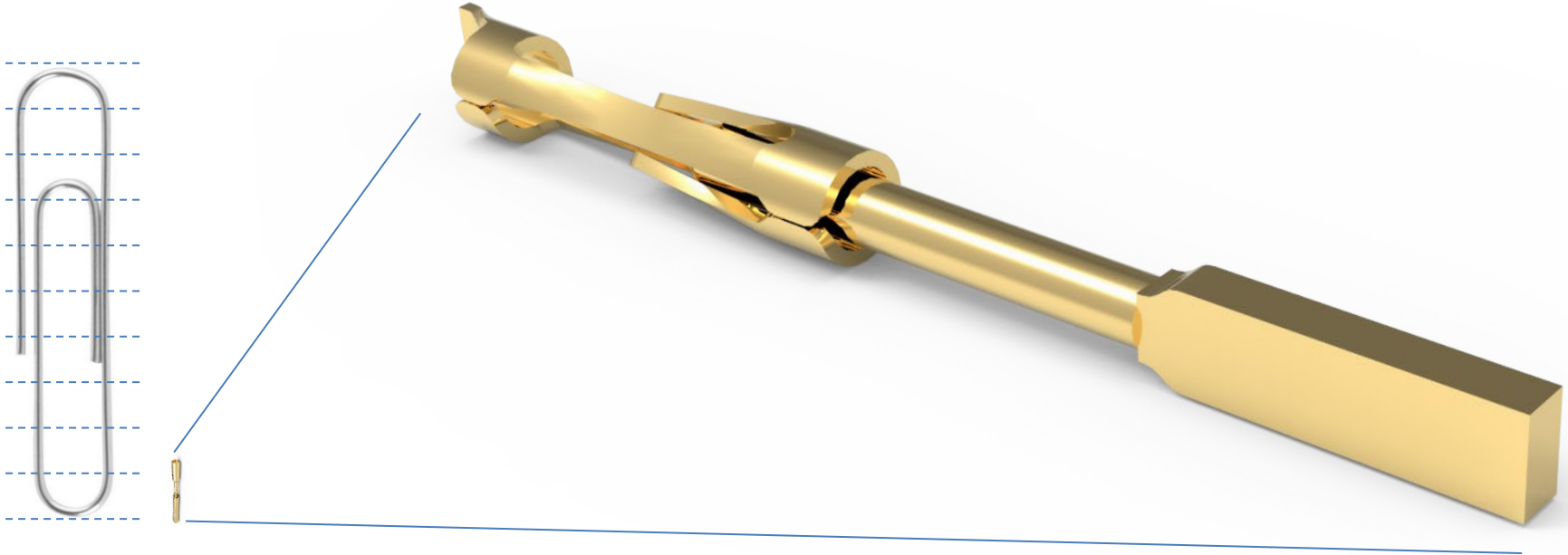

Rugged Metal Shells – Space/Mil-Grade Materials

- Nickel-plated metal shells
- LCP/PPS Molded Insulators
- All non-metallic materials meet space outgassing requirements per ASTM E595
- Epoxy Sealed Contacts/Insulators



Mating/Mounting Hardware

- Guide/Jacking/Locking
- Field replaceable and swappable
- Hardware used to mount connector to PCB
- Integrated into the interface

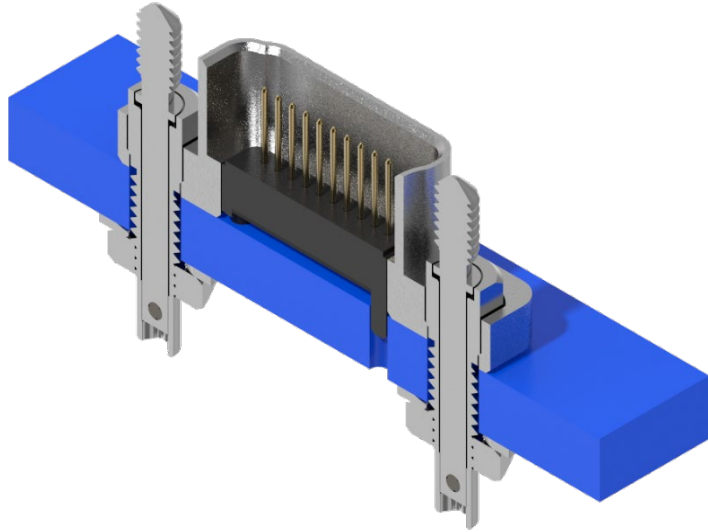

Jacking Hardware



Locking Hardware



Jacknut Hardware



Guide Hardware

Mating Sequence – Fool Proof? Likely Not!

Hardware engages

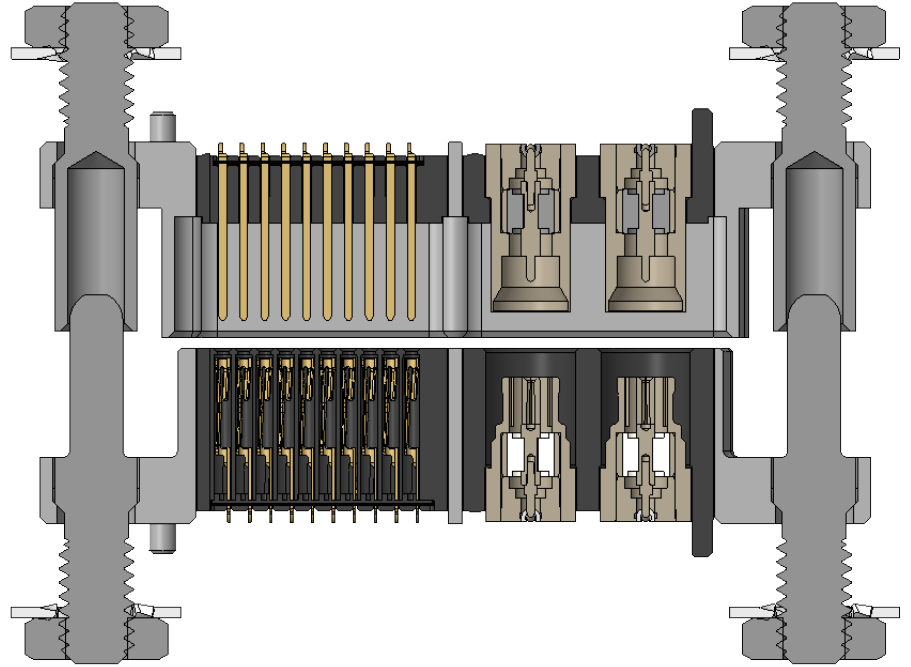

Mating sequence details are also applicable for right-angle connectors and cables.

Mating Sequence – Guide Hardware

Hardware engages



Metal shells engage

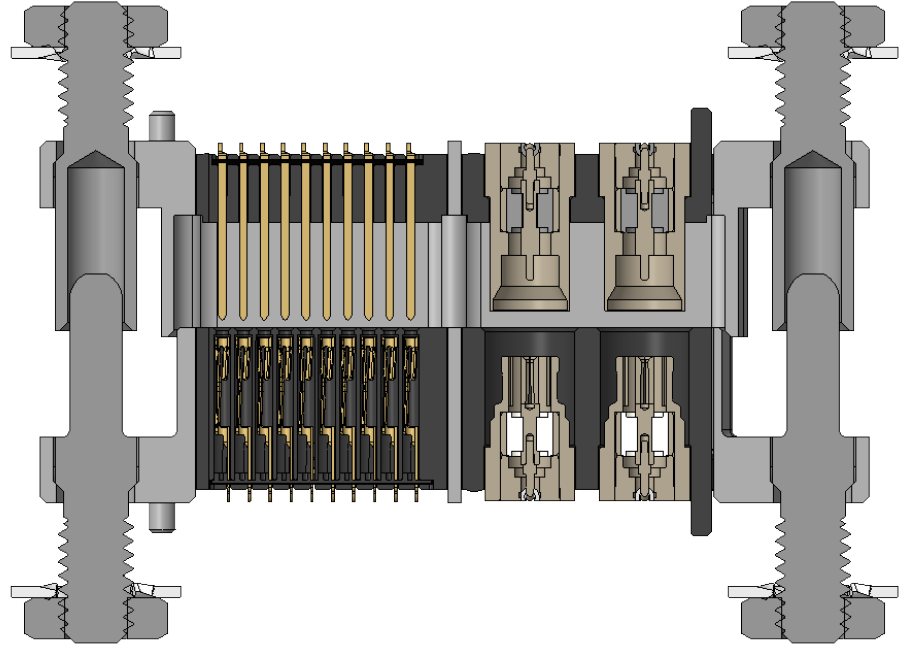

Mating sequence details are also applicable
for right-angle connectors and cables.

Mating Sequence – Guide Hardware

Hardware engages
↓
Metal shells engage
↓
HD pins engage insulator

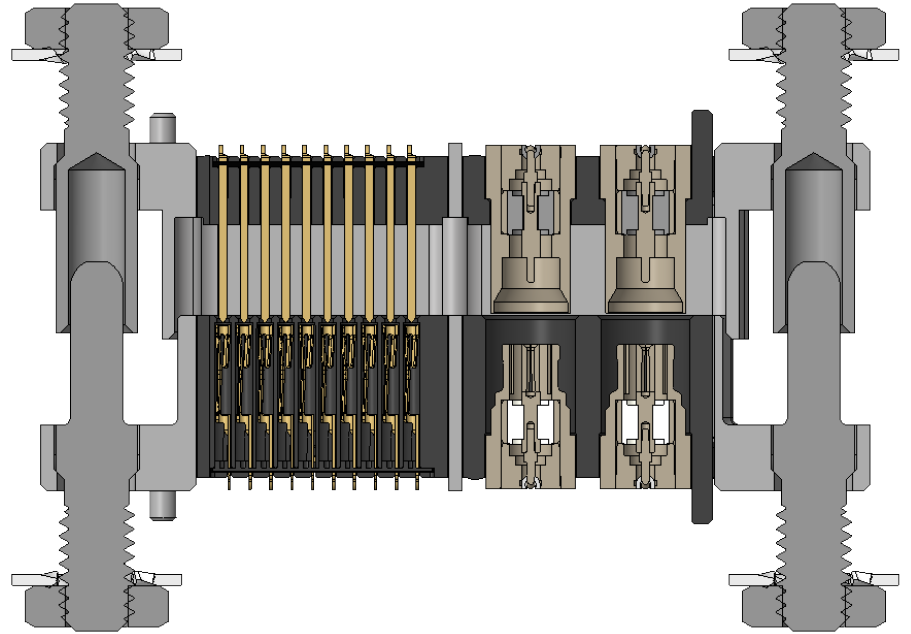

Mating sequence details are also applicable
for right-angle connectors and cables.

Mating Sequence – Guide Hardware

Hardware engages
↓
Metal shells engage
↓
HD pins engage insulator
↓
HD pins engage socket,
RF contacts engage insulator

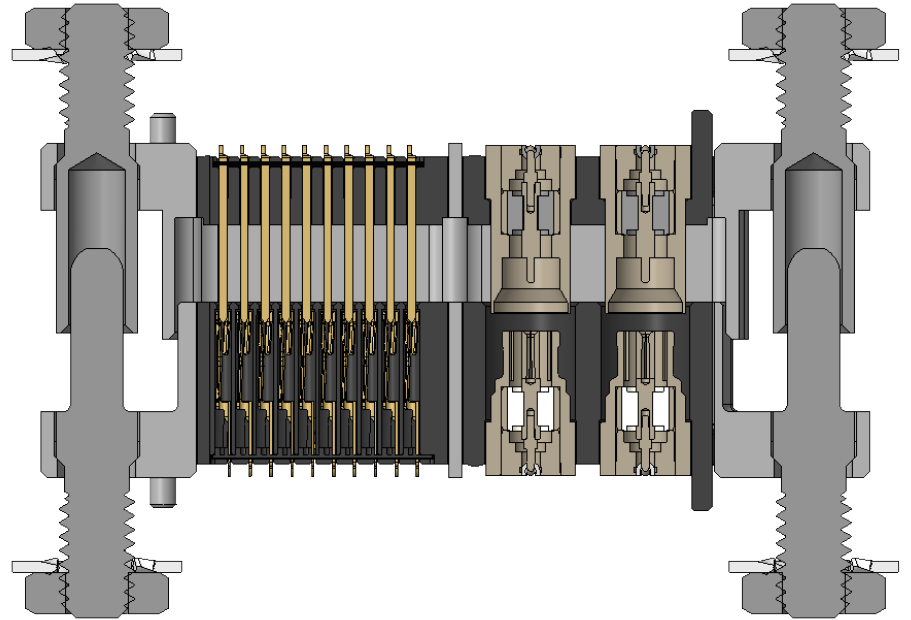

Mating sequence details are also applicable
for right-angle connectors and cables.

Mating Sequence – Guide Hardware

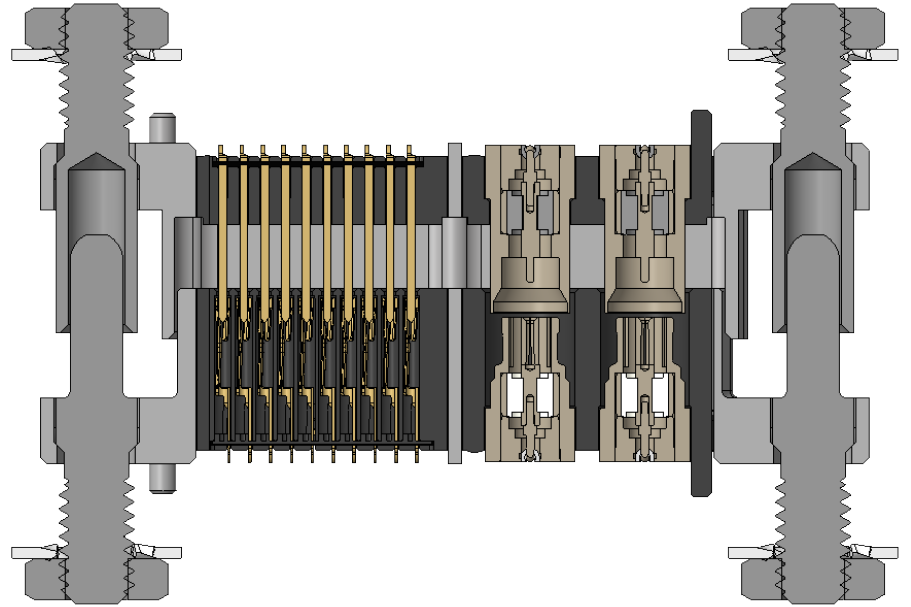
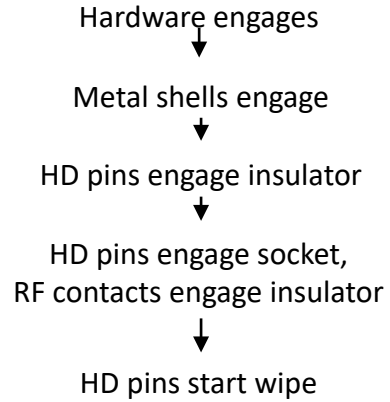

Mating sequence details are also applicable
for right-angle connectors and cables.

Mating Sequence – Guide Hardware

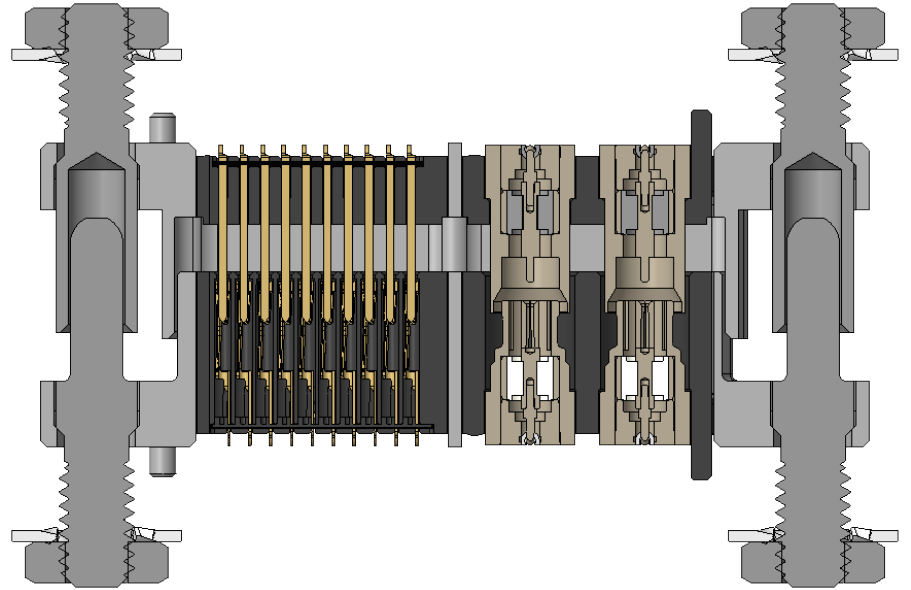
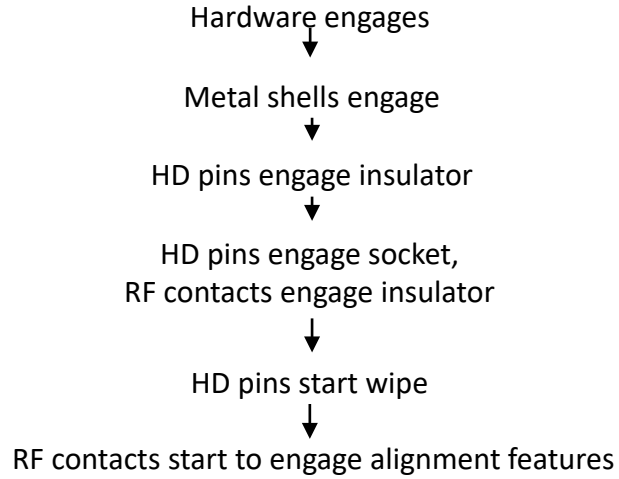

Mating sequence details are also applicable
for right-angle connectors and cables.

Mating Sequence – Guide Hardware

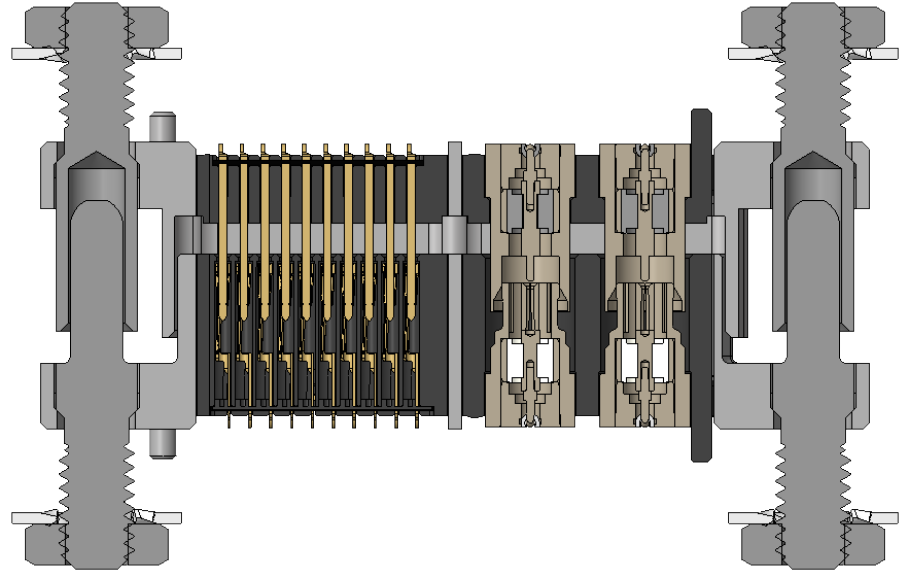
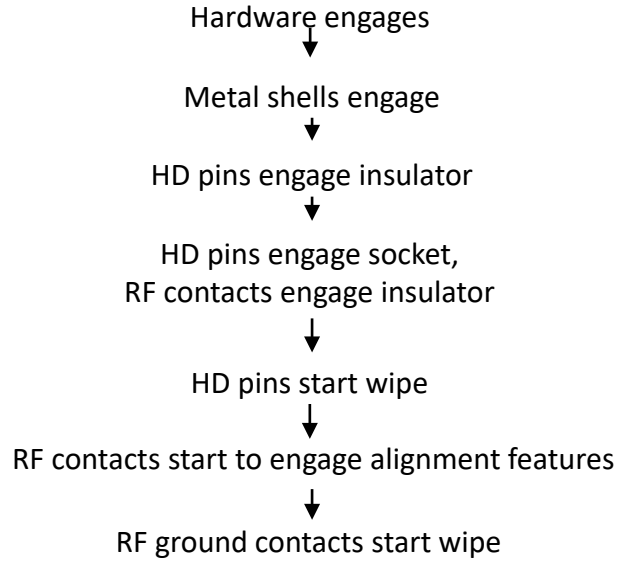

Mating sequence details are also applicable
for right-angle connectors and cables.

Mating Sequence – Guide Hardware

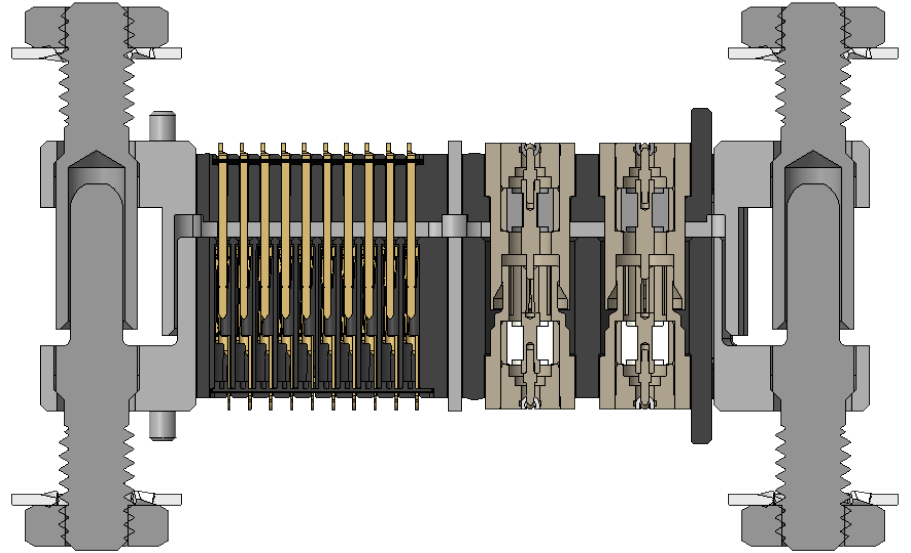
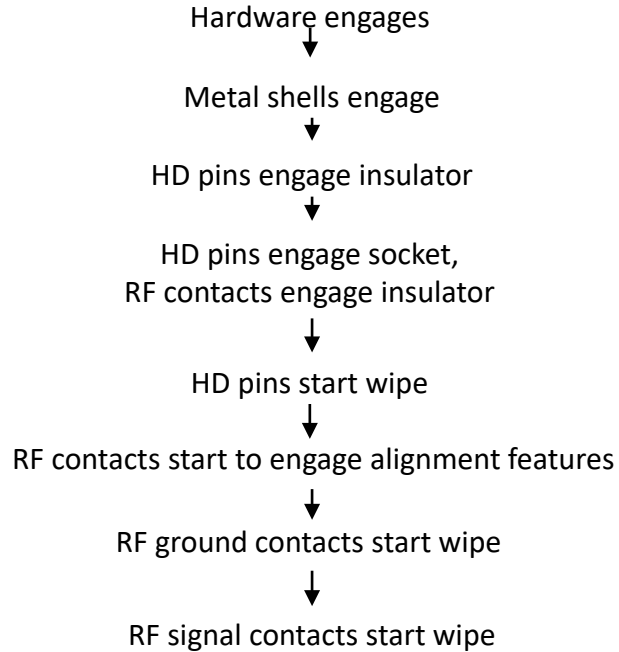

Mating sequence details are also applicable
for right-angle connectors and cables.

Mating Sequence – Guide Hardware

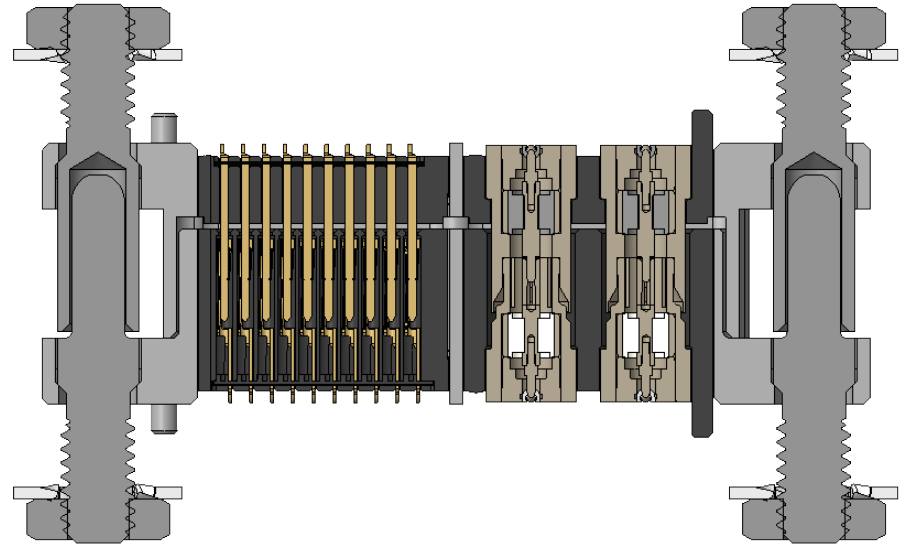
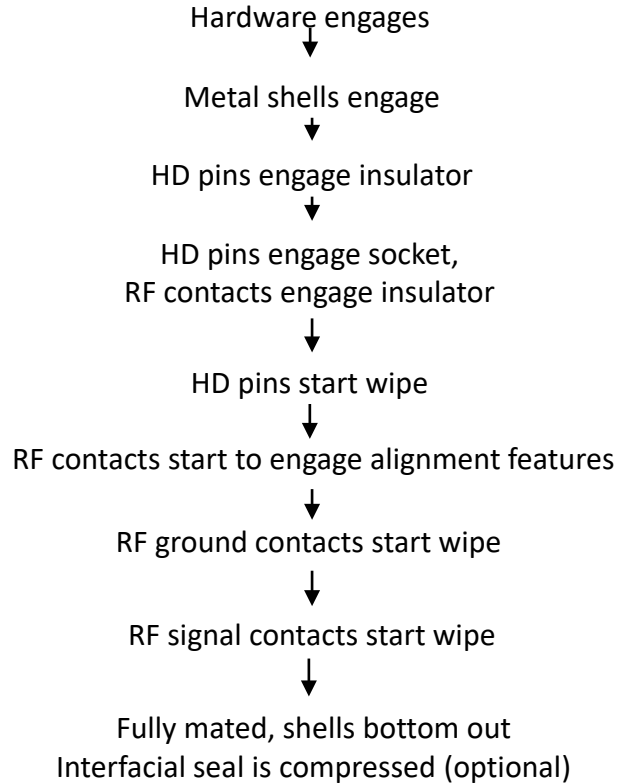

Mating sequence details are also applicable
for right-angle connectors and cables.

Mating Sequence – Guide Hardware

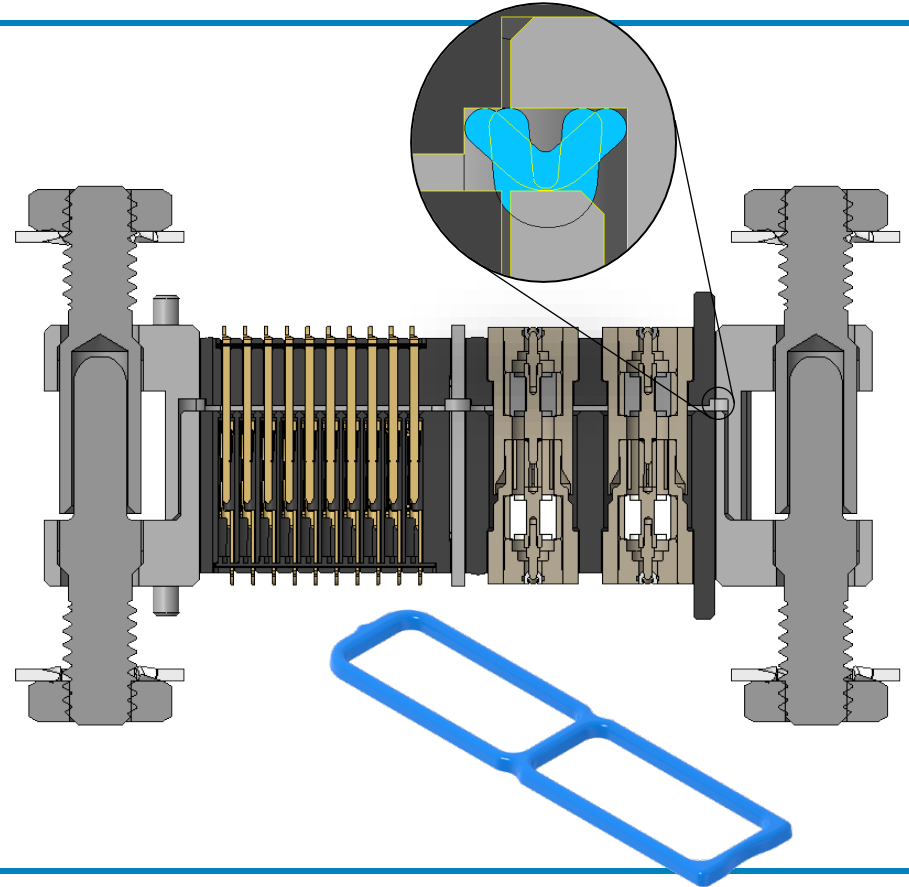
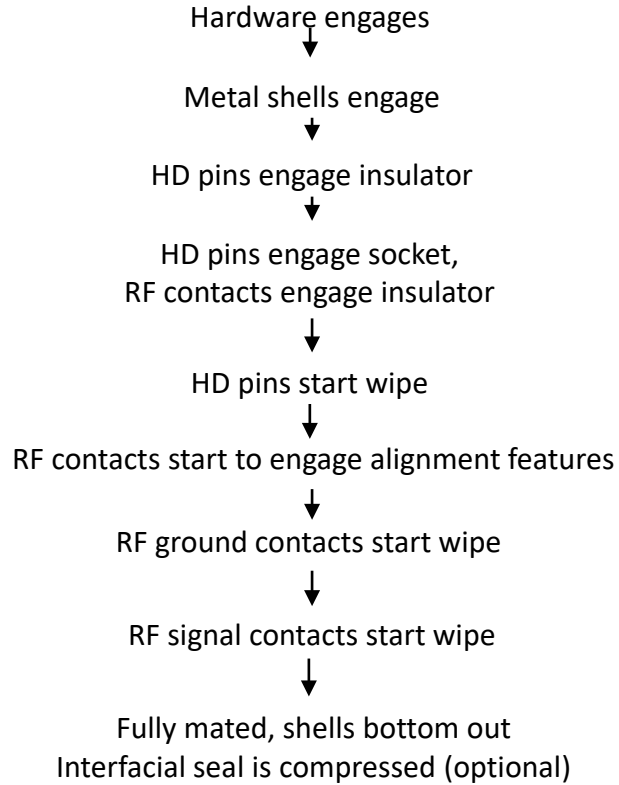

$\pm .030$ Maximum
Misalignment

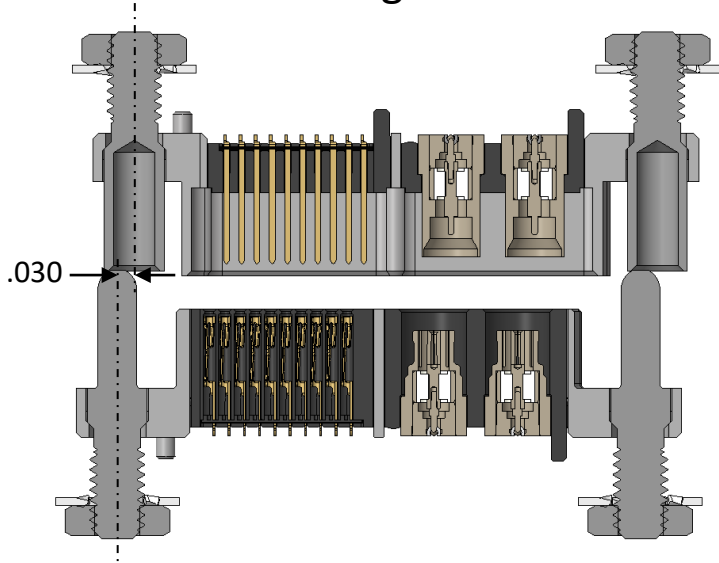

Guide hardware prevents damage
from angular misalignment

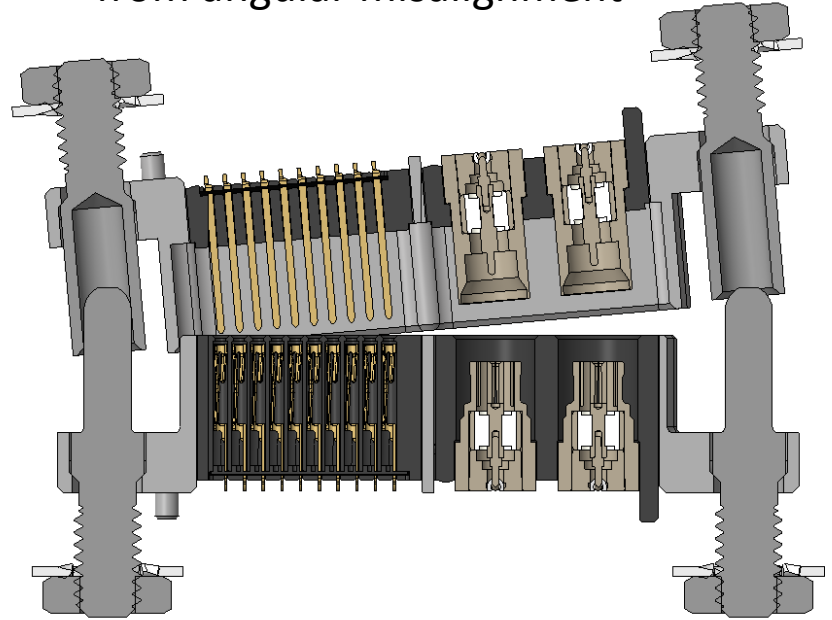

Keyed Interface

Proper mating

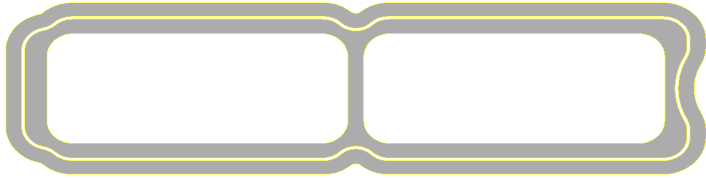

Interface 180° out

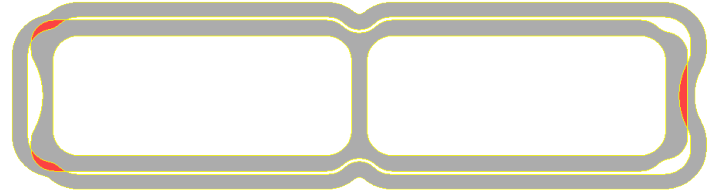

End keys along with the keys between bays prevent Interface from being partially mated at an angle when 180° out

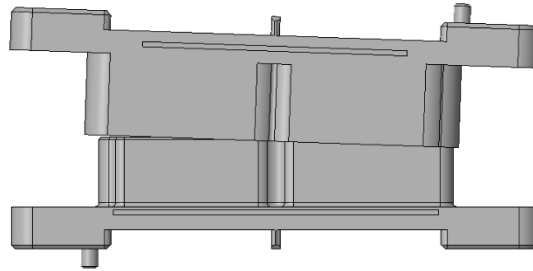

Market Requirements: Voice of the Customer

- Multiple points of contact – **50 μ** Gold
- Availability
- Configurability
- Class 3 SMT
- Mix Signals – Power/Signal/RF
- Metal Shells
- Back sealing
- High Density - .050 or smaller
- High Shock and Vibration – Mil grade or better
- Panel Mountable
- High Speed and LVDS Capable

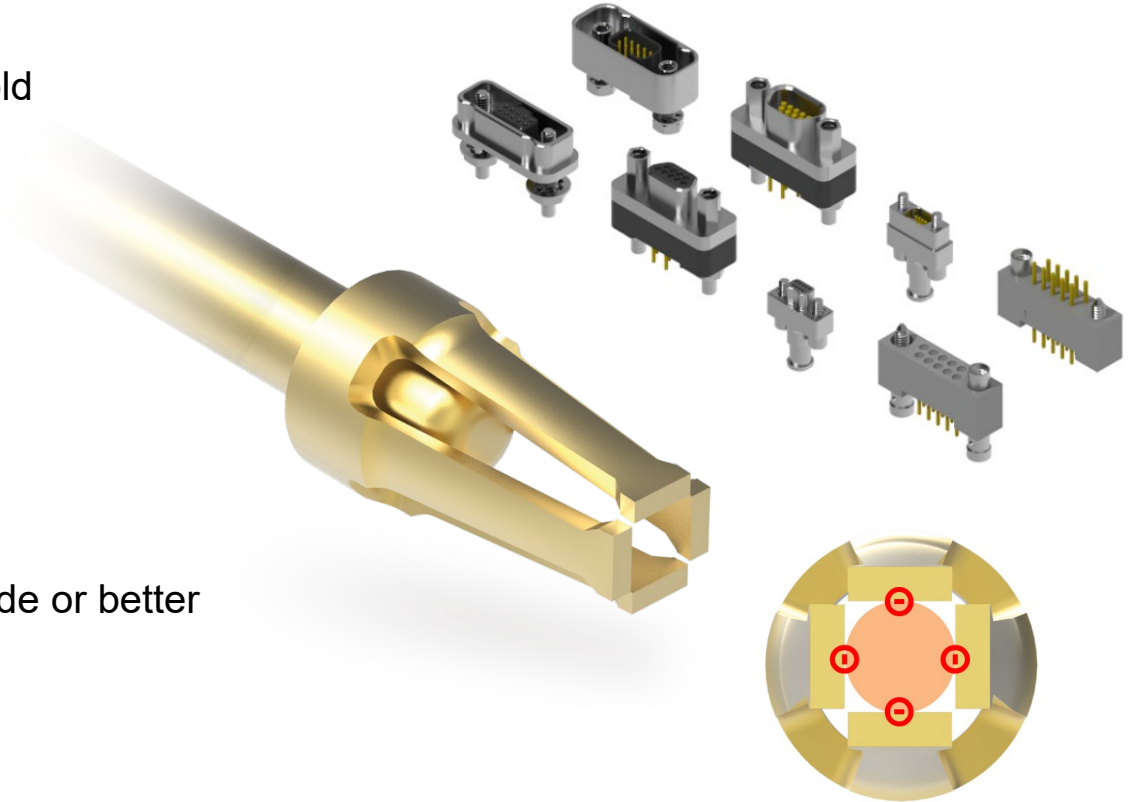



A new contact system designed for reliability, manufacturability, & high-speed capability

- 4 points of contact – x and y axis
- One piece design for vertical, right angle and cable
- IPC-610 Class 3 surface mount capable (J-Lead)
- Optimal normal force for low contact resistance
- Stamped and formed to reduce cost
- Optimized impedance

Industry Applications - 1U - 10cm Cube Sat

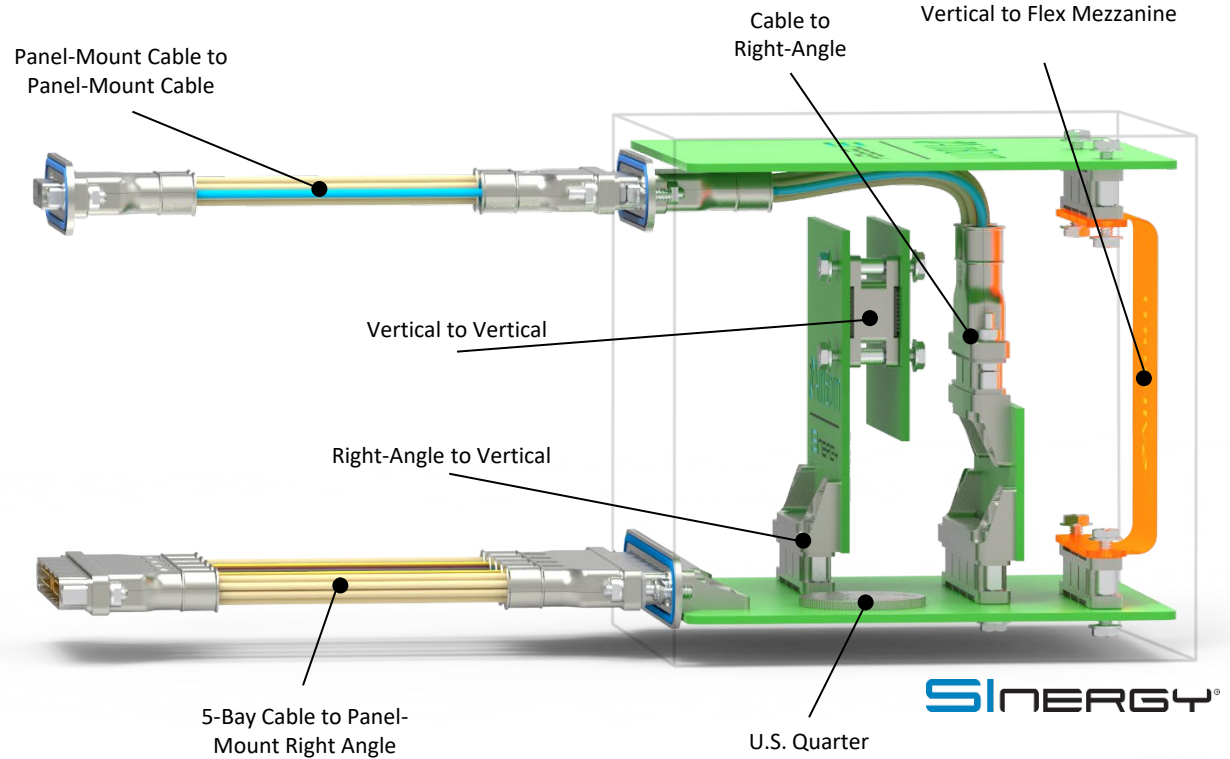
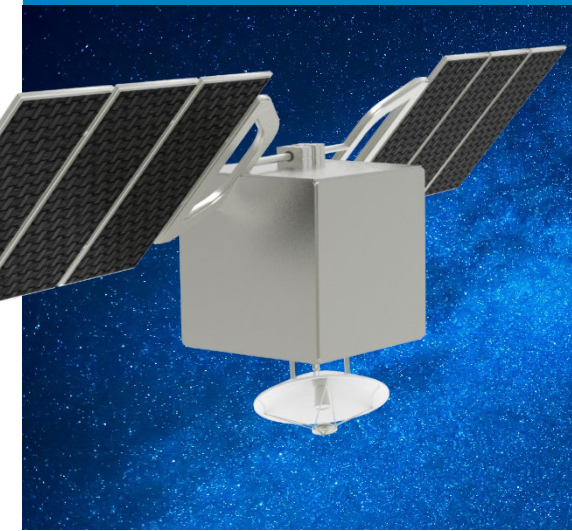



Rugged Interconnects

- **Contact** – Multiple Points/Axis
- **Metal Shells** – Rigidity and Tolerance
- **Materials** – High Strength
- **Alignment Features**
- **SWaP-C**



Thank You!